



Touchscreen Deadbolt with Alarm

# Installation Guide



# PACKAGE CONTENTS

ENGLISH

Camelot Style Shown  
Throughout Guide

Support Plate

Key



Touchscreen  
Assembly

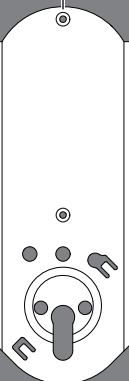
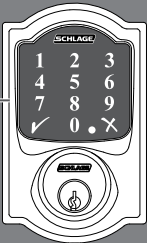

Battery Cover

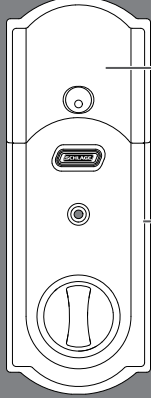

Alarm  
Assembly

Strike

Bolt



Reinforcement  
Plate

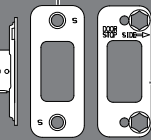

Set Screw (2)  
(1 spare)



Bolt/Strike  
Screws (4)



Alarm Assembly  
Screw



Support Plate  
Screws (2)

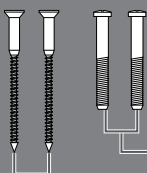

Reinforcement  
Screws (2)



Century Style

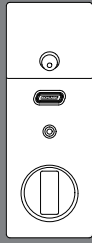

## LET'S GET STARTED!

Once you have all your tools together, please follow each step carefully and in order. Because this is an electronic lock, the order of steps is very important. If you skip a step, you may have to perform a factory default reset and start over.

### You will definitely need this tool:

- Phillips screwdriver  
You can use a manual or electric screwdriver, but please DO NOT use a power drill!

### You may also need these tools:

- Tape Measure
- Flathead Screwdriver
- Pencil
- Wood Block
- Hammer

## INSTALLATION NOTES PLEASE READ!

- DO NOT use a power drill for installation! This could damage the lock.
- Please read all the instructions before calling customer support.
- **Please call customer support before returning the product to the store.**
- DO NOT install the batteries before installing the lock! Follow the instructions in order!
- If you have previously installed this lock on another door, you MUST perform a Factory Default Reset FIRST! See the User's Guide for more information.
- This lock is designed for the following operating temperatures:
  - Outside Lock Body (exterior mounted): -31°F (-35°C) to 151°F (66°C)
  - Inside Lock Body (interior mounted): 14°F (-10°C) to 120°F (49°C)

## STEPS AT A GLANCE

1	Check current door/frame alignment.....	4
2	Remove the current deadbolt from the door.....	4
3	Check door/frame dimensions.....	5
4	Locate programming and User Codes. ....	5
5	Install Bolt and Strike .....	6
5a	Adjust bolt length, if necessary. ....	6
5b	Change to the round bolt faceplate, if necessary.....	6
5c	Install the bolt into the door.....	7
5d	Install the strike into the frame. ....	7
5e	Test bolt alignment.....	8
6	Install the Touchscreen Assembly. ....	8
6a	Install the Touchscreen on the outside of the door.....	8
6b	Install the Support Plate on the inside of the door.....	9
7	Install the Alarm Assembly .....	9
7a	Remove the battery cover from the Alarm Assembly. ....	9
7b	Connect the cable to the Alarm Assembly.....	10
7c	Install the Alarm Assembly.....	10
7d	Secure the Alarm Assembly to the Support Plate.....	11
8	Install the Batteries.....	11
8a	Install the batteries into the battery tray. ....	11
8b	Install the battery cover.....	11
9	Set up the Lock. ....	12
10	Test the Lock. ....	12
10a	Extend the bolt (lock) using the inside thumbturn.....	12
10b	Extend the bolt (lock) using the Touchscreen.....	13
10c	Retract the bolt (unlock) using the Touchscreen. ....	13
10d	If the lock failed to lock or unlock:.....	13
11	Continue to the User's Guide.....	14

## 1 Check current door/frame alignment.

Because the bolt on this lock is extended automatically, it is important that the door and frame are aligned. Use this checklist to determine if your current alignment will work without any adjustment.

- I can lock the door without pushing, pulling or lifting the door.
- My door alignment— the ability to lock the door easily and smoothly— stays the same with changing seasons.
- When the door is closed, there is space for the deadbolt to extend 1" into the frame when locked.

If you could not check every box in the checklist, you will need to adjust your door and/or frame. Please visit [answers.schlage.com](http://answers.schlage.com) for more information.

## 2 Remove the current deadbolt from the door.

Remove the entire deadbolt, including the bolt. You may also want to remove the strike.

- ① In order to maintain BHMA Grade 1, you must install the included reinforcement plate and strike (**see step 5d on page 7**).
- ① A standard Schlage deadbolt is shown. Check with your specific deadbolt manufacturer if you need help.

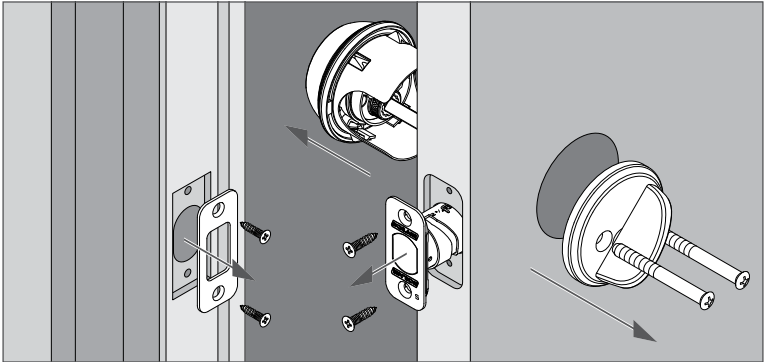

### 3 Check door/frame dimensions.

- Measure the dimensions shown. If your door dimensions do not match, you will need to change your door preparation. Go to [answers.schlage.com](http://answers.schlage.com) for drilling instructions.

① If your door is thicker than 1 $\frac{3}{4}$ " , you will need a thick door kit. Please call Customer Service:

① Remember your **backset** measurement. You will need this for the next step. Either measurement is normal.

Toll-Free Calling From:  
U.S.A.: (888) 805-9837  
Canada: (800) 997-4734  
Mexico: 018005067866

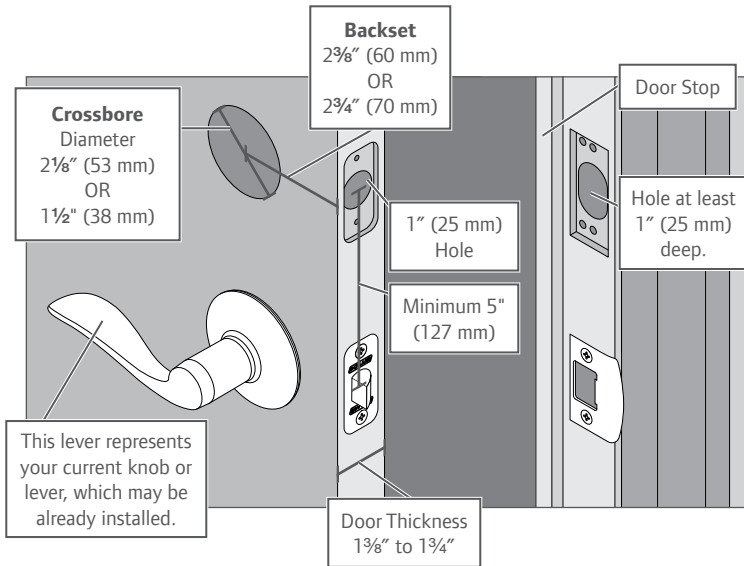

### 4 Locate programming and User Codes.

Codes are located on the sticker on the **back of the User's Guide**. You will need these codes to operate the lock. They are also located on the **back of the Alarm Assembly**.

① Do NOT remove the sticker from the back of the lock! If you lose your Programming Code, you can reset your lock back to these default codes.

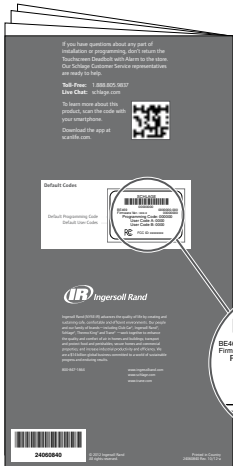

The same codes are located in both places.

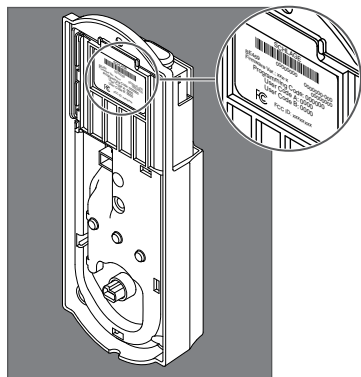

## 5 Install bolt and strike.

### 5a Adjust bolt length, if necessary.

- If the **backset** (see step 3) of your door was  $2\frac{3}{8}$ " (60 mm), you do not need to do anything. Proceed to step 5b.
- If the **backset** (see step 3) of your door was  $2\frac{3}{4}$ " (70 mm), you need to adjust your bolt. Twist the faceplate until the button pops into the  $2\frac{3}{4}$ " space.

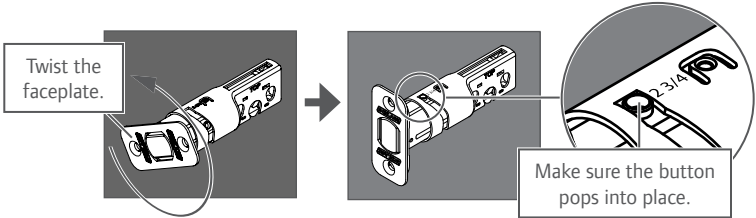

### 5b Change to the round bolt faceplate, if necessary.

- If the edge of your door has a **mortise**, you do not need to do anything. Proceed to step 5c.
- If the edge of your door has **no mortise**, change the faceplate on your bolt.

① In step 5c, your installation will depend on which kind of door edge you had in this step.

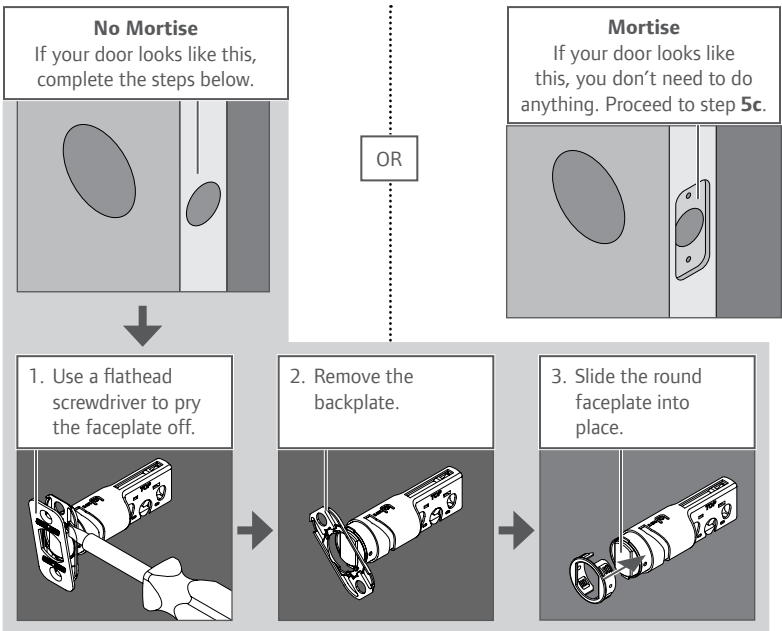

## 5c Install the bolt into the door.

Chose the picture below that matches your door.

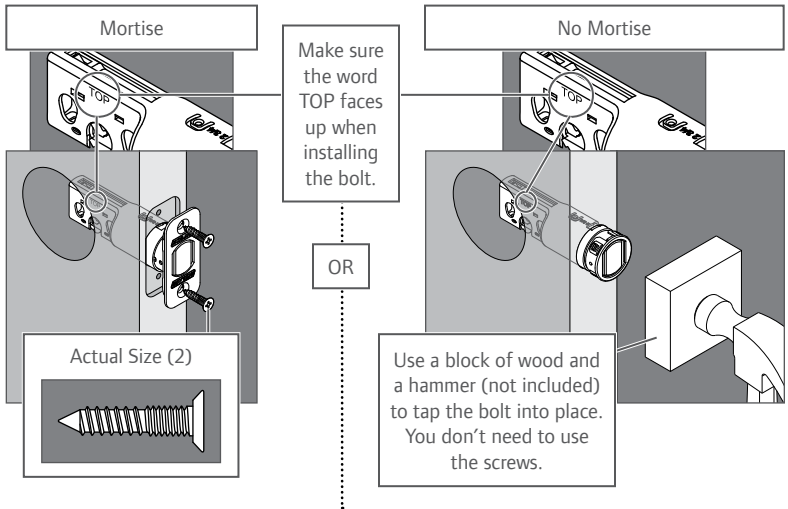

## 5d Install the strike into the frame.

Install all the parts shown for maximum security.

- ① In order to maintain BHMA Grade 1, you must install the included reinforcement plate and strike.

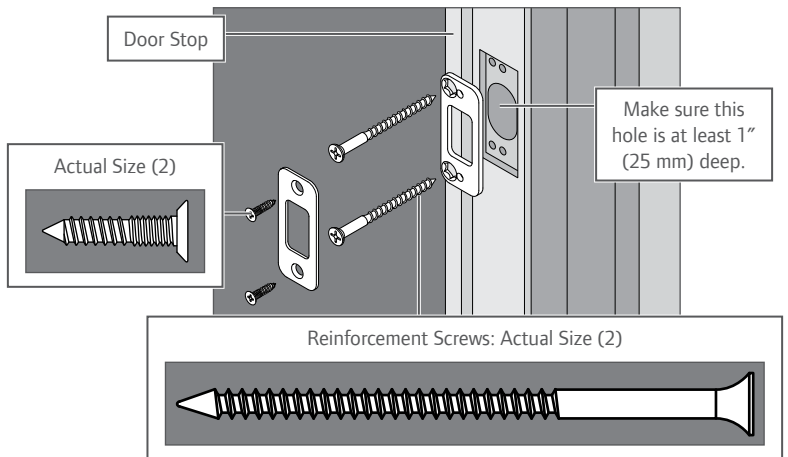

- ① The reinforcement screws may not fit on doors with sidelights.

## 5e Test bolt alignment.

1. Close the door.
2. Insert a flathead screwdriver into the slot in the bolt, as shown.
3. Rotate the screwdriver toward the door edge to extend the bolt into the hole in the frame. This operation should be smooth. You should be able to rotate the screwdriver 90°, fully extending the bolt.
4. If the operation was not smooth, or if the bolt did not fully extend, adjust your frame and/or door preparation. Go to [answers.schlage.com](http://answers.schlage.com) for further instructions.
5. Retract (unlock) the bolt before continuing to step 6.

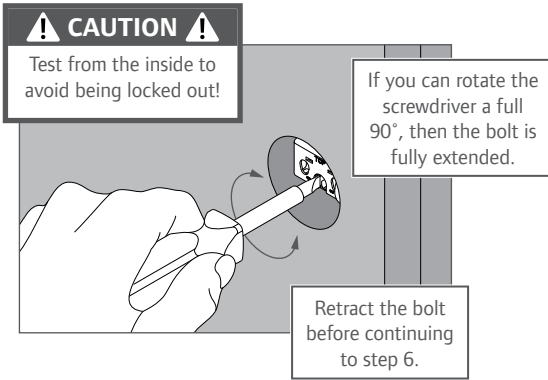

## 6 Install the Touchscreen Assembly.

### 6a Install the Touchscreen on the outside of the door.

- ① The clips snap into the **crossbore** (see step 3 on page 5) to assist in holding the keypad on the door.
- ① The Touchscreen Assembly should install smoothly. If it does not, check that the bolt is set to the correct **backset** (see step 5a on page 6).

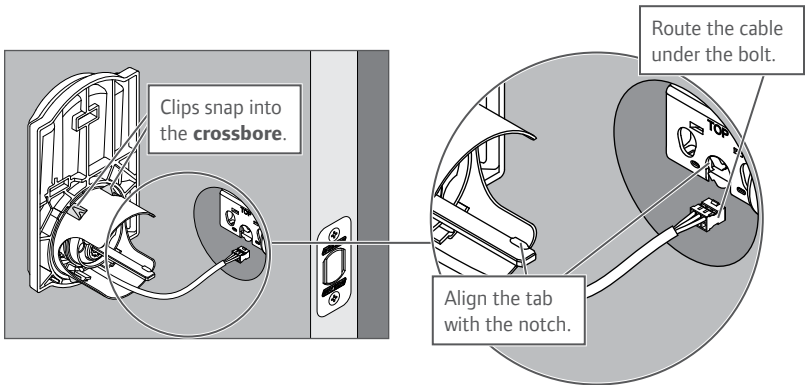

- ① NOTE: If you have a 1½" (38 mm) **crossbore** (see step 3 on page 5), please see **Spacer Removal** on page 15.



## 6b Install the Support Plate on the inside of the door.

- ① Make sure the Touchscreen and Support Plate are straight on the door before tightening the screws. Tighten screws fully to prevent the lock from moving over time.

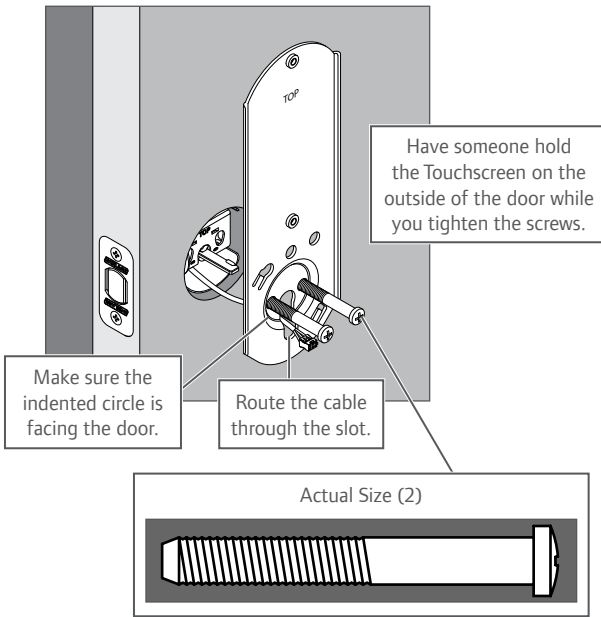

## 7 Install the Alarm Assembly.

### 7a Remove the battery cover from the Alarm Assembly.

#### ELECTROSTATIC DISCHARGE WARNING!



DO NOT TOUCH the circuit board! You may damage the lock.

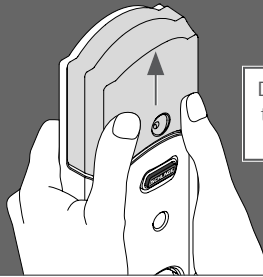

DO NOT remove the battery tray (not shown)!

## 7b Connect the cable to the Alarm Assembly.

① Locate the screws in step 7d before beginning this step so they will be handy when you need them.

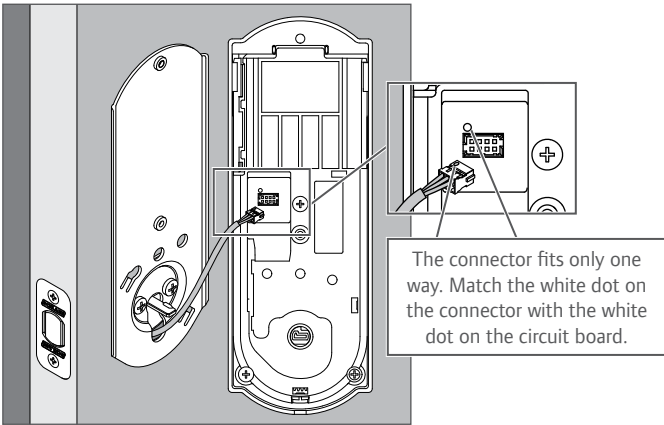

## 7c Install the Alarm Assembly.

1. Align the tab with the notch as shown.
2. Route the cable into the channel.
3. Then slide the Alarm Assembly towards the door.

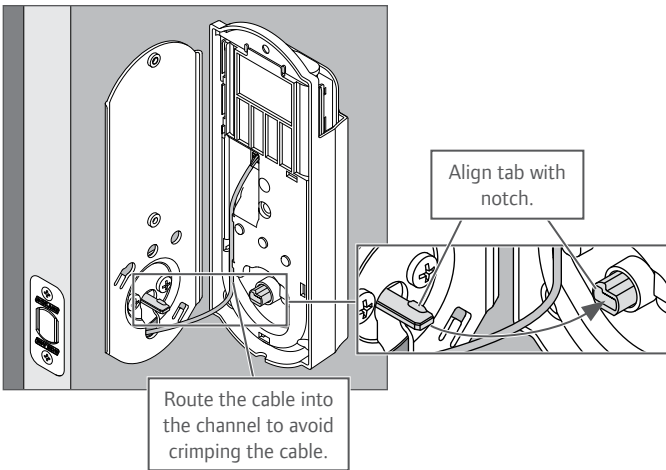

## 7d Secure the Alarm Assembly to the Support Plate.

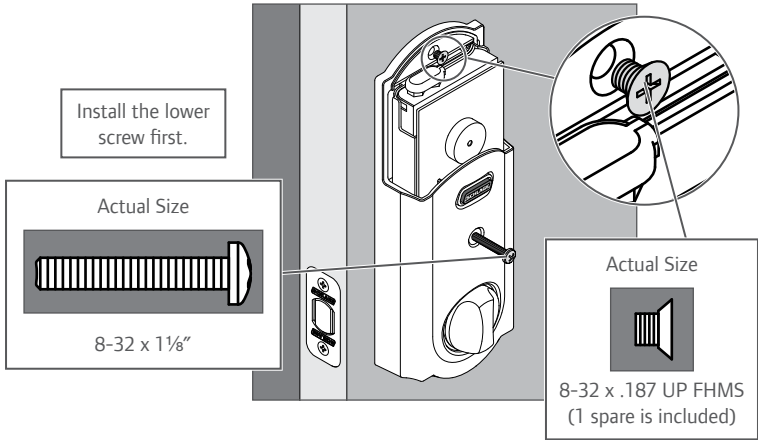

Do not turn the thumbturn at this time. Testing will be completed after the lock is completely installed.

## 8 Install the Batteries.

### 8a Install the batteries into the battery tray.

1. Unsnap the connector.
2. Remove the battery tray.
3. Install four high-quality alkaline AA batteries.
  - ⓘ Lithium batteries may cause undesirable operation.
4. **Carefully** replace the battery tray, with the batteries facing the door.
5. Snap the connector back into place.

#### ELECTROSTATIC DISCHARGE WARNING!



DO NOT TOUCH the circuit board! You may damage the lock.

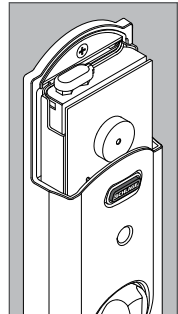
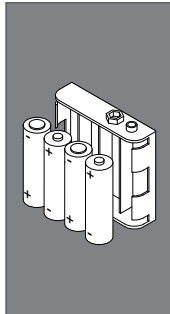
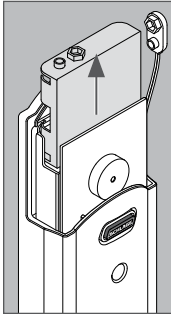

### 8b Install the battery cover.

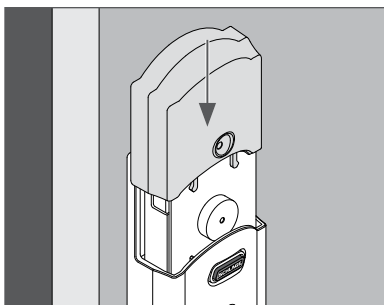

## 9 Set up the Lock.

1. Open the door if it is not already open.
  2. Press the Outside Schlage Button.
  3. Enter one of the Default User Codes into the lock (**see step 4 on page 5**).
  4. The lock will perform a setup routine. Wait until the bolt stops moving before continuing.
- ① If the Touchscreen did not light up during this step, you may have a power problem. Install fresh batteries and make sure the battery wires are connected (**see step 8a on page 11**). If that does not help, make sure the cable is connected and is not crimped (**see step 7b on page 10**).

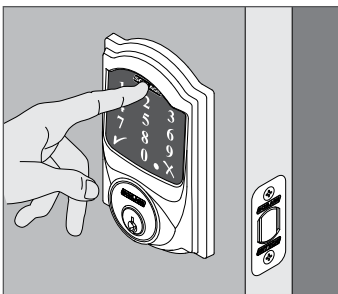

## 10 Test the Lock.



Keep the key with you during testing to avoid being locked out!

- ① For complete information about programming and light/beep patterns, see the **Programming the Touchscreen** and **Troubleshooting** sections in the **User's Guide**.

### 10a Extend the bolt (lock) using the inside thumbturn.

1. Close the door.
2. Rotate the thumbturn toward the door jamb to extend the bolt.

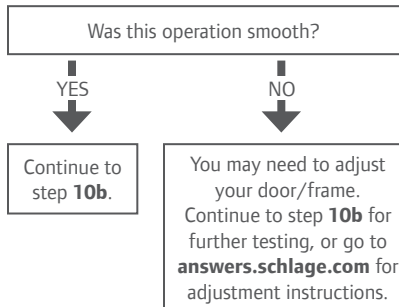

## 10b Extend the bolt (lock) using the Touchscreen.

1. Unlock the door using the thumbturn if you have not already.
2. **Take the key with you!** Go outside and close the door.
3. Press the Outside Schlage Button.
4. The bolt should extend.

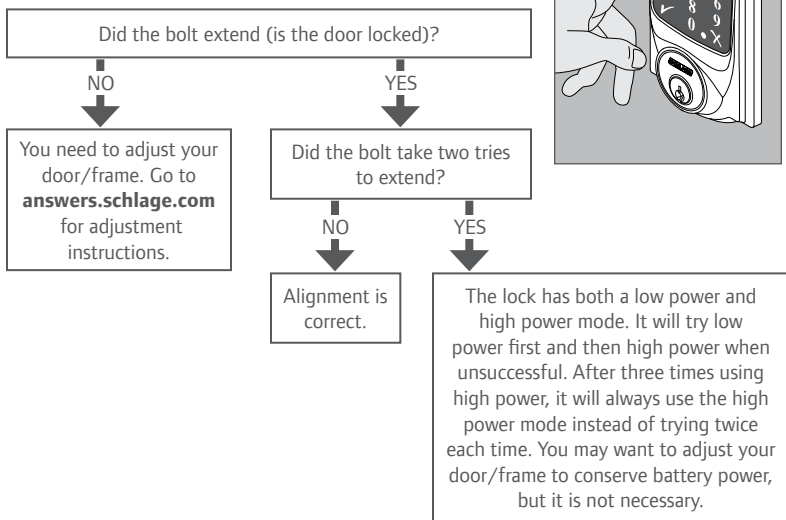
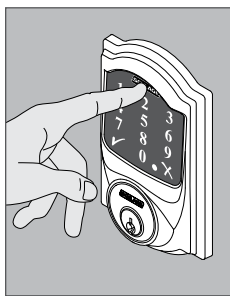

## 10c Retract the bolt (unlock) using the Touchscreen.

1. Press the Schlage button.
2. Enter one of the default User Codes into the lock (see **step 4 on page 5**).
3. The bolt should retract.

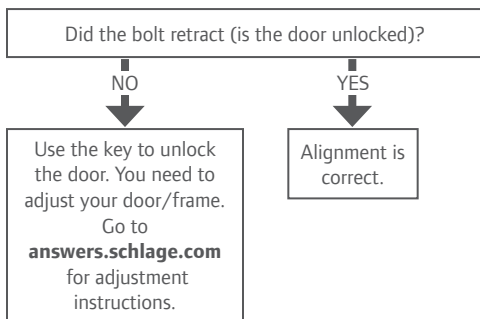
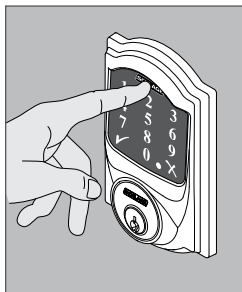

## 10d If the lock failed to lock or unlock:

1. If the Touchscreen did not light up, you may have a power problem. Install fresh batteries and make sure the battery connector is connected (see **step 8a on page 11**). If that does not help, make sure the cable is connected to the Alarm Assembly and is not crimped (see **step 7b on page 10**).
2. If the lock had power but you need to adjust your door/frame, please go online to [answers.schlage.com](http://answers.schlage.com) for complete adjustment instructions and videos.

## 11 Continue to the User's Guide.

Your lock is installed and functional. Continue to the User's Guide for complete information about how to configure and operate the lock and alarm.

## SPACER REMOVAL

ONLY if your door has a 1½" (38 mm) **crossbore**, remove the spacer as shown.

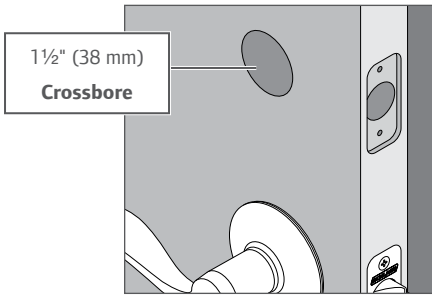

1. Remove screw.

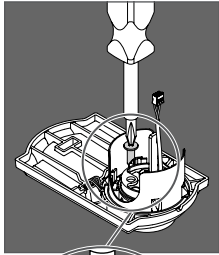

2. Rotate and remove spacer.

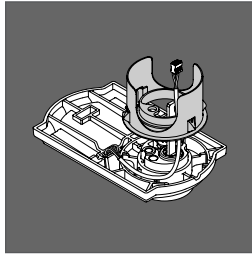

3. Replace screw.

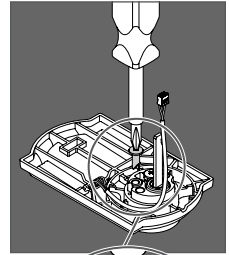

### NEED HELP?

Please call customer support before returning the product to the store.

Toll-Free Calling From: U.S.A.: (888) 805-9837  
Canada: (800) 997-4734  
Mexico: 018005067866

Visit our web site for videos, FAQs and more: [answers.schlage.com](http://answers.schlage.com)

If you have questions about any part of installation or programming, don't return the Touchscreen Deadbolt with Alarm to the store. Our Schlage Customer Service representatives are ready to help.

**Toll-Free:**

1.888.805.9837

**Live Chat:** [schlage.com](http://schlage.com)

To learn more about this product, scan the code with your smartphone.

Download the app at [scanlife.com](http://scanlife.com).

Si tiene dudas acerca de cualquier parte de la instalación o programación, no devuelva el cerrojo de pantalla táctil con alarma a la tienda. Nuestros representantes del Departamento de Servicio de Asistencia al Cliente de Schlage están listos para ayudarlo.

**Línea gratuita:**

1.888.805.9837

**Chat en vivo:** [schlage.com](http://schlage.com)

Para obtener más información sobre este producto, escanee el código con un teléfono inteligente.

Descargue la aplicación en [scanlife.com](http://scanlife.com).

Si vous avez des questions concernant l'installation ou programmation, ne ramenez pas le pêne dormant avec écran tactile muni d'une alarme au magasin. Les représentants du service à la clientèle de Schlage sont à votre service.

**Sans frais :**

1.888.805.9837

**Clavardage en direct :** [schlage.com](http://schlage.com)

Pour de plus amples renseignements sur ce produit, numérisez le code avec votre téléphone intelligent.

Téléchargez l'application au [scanlife.com](http://scanlife.com).



Ingersoll Rand (NYSE:IR) advances the quality of life by creating and sustaining safe, comfortable and efficient environments. Our people and our family of brands—including Club Car<sup>®</sup>, Ingersoll Rand<sup>®</sup>, Schlage<sup>®</sup>, Thermo King<sup>®</sup> and Trane<sup>®</sup>—work together to enhance the quality and comfort of air in homes and buildings; transport and protect food and perishables; secure homes and commercial properties; and increase industrial productivity and efficiency. We are a \$14 billion global business committed to a world of sustainable progress and enduring results.

800-847-1864

[www.ingersollrand.com](http://www.ingersollrand.com)  
[www.schlage.com](http://www.schlage.com)  
[www.trane.com](http://www.trane.com)

Ingersoll Rand (NYSE:IR) mejora la calidad de vida por medio de la creación y el sostenimiento de entornos seguros, confortables y eficaces. Nuestro personal y nuestra familia de marcas —que incluye Club Car<sup>®</sup>, Ingersoll Rand<sup>®</sup>, Schlage<sup>®</sup>, Thermo King<sup>®</sup> y Trane<sup>®</sup>— trabajan en conjunto para mejorar la calidad y el confort del aire en casas y edificios, transportan y protegen alimentos y productos perecederos, aseguran hogares y propiedades comerciales y aumentan la productividad y la eficiencia industrial. Somos una empresa mundial de 14.000 millones de dólares comprometida con un mundo de progreso sostenible y resultados duraderos.

800-847-1864

[www.ingersollrand.com](http://www.ingersollrand.com)  
[www.schlage.com](http://www.schlage.com)  
[www.trane.com](http://www.trane.com)

Ingersoll Rand (NYSE:IR) améliore la qualité de vie en créant et en entretenant des milieux sains, confortables et efficaces. Notre personnel et notre famille de marques (dont Club Car<sup>MD</sup>, Hussmann<sup>MD</sup>, Ingersoll Rand<sup>MD</sup>, Schlage<sup>MD</sup>, Thermo King<sup>MD</sup> et Trane<sup>MD</sup>) collaborent pour améliorer la qualité de l'air et le confort dans les maisons et les immeubles, le transport et la protection des aliments et des denrées périssables, la sécurité des maisons et des propriétés commerciales et la productivité et le rendement industriels. Nous sommes une entreprise de 14 milliards qui croit en un monde de progrès et de résultats durables.

800-847-1864

[www.ingersollrand.com](http://www.ingersollrand.com)  
[www.schlage.com](http://www.schlage.com)  
[www.trane.com](http://www.trane.com)



24060840

© 2012 Ingersoll Rand  
All rights reserved.

24060840 Rev. 12/12-b